

8080, 8081, 8082 EZ Pivot Door Slide

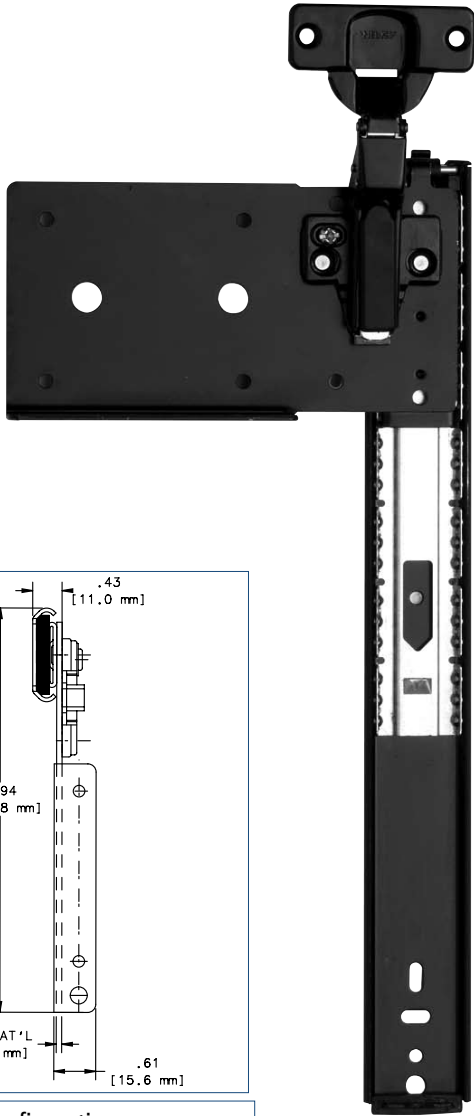

Number	8080EZ 3/4 Extension Slide Packaged With Self-Close 35mm Hinge 8081EZ 3/4 Extension Slide Packaged Without Hinge and Base 8082EZ 3/4 Extension Slide Packaged With Attached Hinge Base																	
Mounting Side	Slide																	
Action	Ball Bearing Movement																	
Load Rating	30-Pound Class																	
Maximum Dimensions	Horizontal Pivot Doors: 24" High x 48" Wide Vertical Doors: 42" High x 24" Wide																	
Clearance	Maximum Slide Width Including Hinges:																	
	<table border="1"> <thead> <tr> <th>Type</th> <th>Standard</th> <th>Salice</th> </tr> </thead> <tbody> <tr> <td>Self-Close Hinge</td> <td>1-23/32"</td> <td>1-21/32"</td> </tr> <tr> <td>Free-Swing Hinge</td> <td>1-23/32"</td> <td>1-21/32"</td> </tr> <tr> <td>Overlay Hinge</td> <td>1-23/32"</td> <td>1-7/8"</td> </tr> <tr> <td>Thick Door Hinge</td> <td>2-3/32"</td> <td></td> </tr> <tr> <td>Extra-Thick Door Hinge</td> <td>2-13/32"</td> <td>2-5/16"</td> </tr> </tbody> </table>	Type	Standard	Salice	Self-Close Hinge	1-23/32"	1-21/32"	Free-Swing Hinge	1-23/32"	1-21/32"	Overlay Hinge	1-23/32"	1-7/8"	Thick Door Hinge	2-3/32"		Extra-Thick Door Hinge	2-13/32"
Type	Standard	Salice																
Self-Close Hinge	1-23/32"	1-21/32"																
Free-Swing Hinge	1-23/32"	1-21/32"																
Overlay Hinge	1-23/32"	1-7/8"																
Thick Door Hinge	2-3/32"																	
Extra-Thick Door Hinge	2-13/32"	2-5/16"																
Finish	Anochrome (ANO), Ebony Black (EB)																	
Key Features	<ul style="list-style-type: none"> Cushioned stops and door hold-out 3-Way adjustable door hinge 																	

Size, Finish, & Pack Availability

Available Pack Configurations		Screws
Poly (P)	1 Set per Bag; 10 Sets per Carton	Yes
Quantity (Q)	20 Sets; Multiple Cartons	No

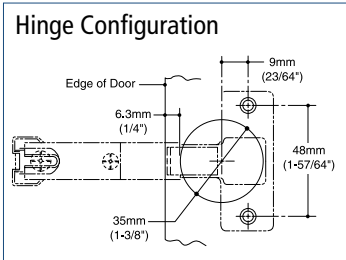
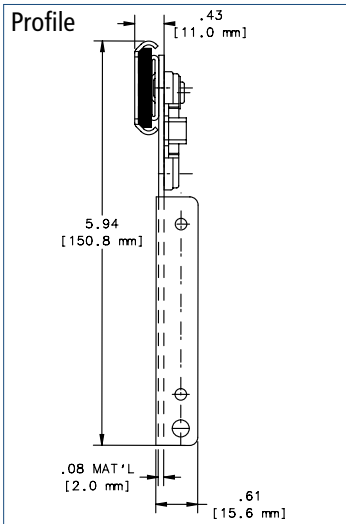

8080EZ Anochrome (ANO) Finish		
Includes Hinges and Bases		
Size	Poly (P)	Quantity (Q)
12 in.	8080PEZ 12	8080QEZ 12
14 in.	8080PEZ 14	8080QEZ 14
16 in.	8080PEZ 16	8080QEZ 16
18 in.	8080PEZ 18	8080QEZ 18
20 in.	8080PEZ 20	8080QEZ 20
22 in.	8080PEZ 22	8080QEZ 22
24 in.	8080PEZ 24	8080QEZ 24

8080EZ Ebony Black (EB) Finish		
Includes Hinges and Bases		
Size	Poly (P)	Quantity (Q)
12 in.	8080PEZ EB 12	8080QEZ EB 12
14 in.	8080PEZ EB 14	8080QEZ EB 14
16 in.	8080PEZ EB 16	8080QEZ EB 16
18 in.	8080PEZ EB 18	8080QEZ EB 18
20 in.	8080PEZ EB 20	8080QEZ EB 20
22 in.	8080PEZ EB 22	8080QEZ EB 22
24 in.	8080PEZ EB 24	8080QEZ EB 24

8081EZ Anochrome (ANO) Finish		
No Hinges or Bases		
Size	Poly (P)	Quantity (Q)
12 in.	8081PEZ 12	8081QEZ 12
14 in.	8081PEZ 14	8081QEZ 14
16 in.	8081PEZ 16	8081QEZ 16
18 in.	8081PEZ 18	8081QEZ 18
20 in.	8081PEZ 20	8081QEZ 20
22 in.	8081PEZ 22	8081QEZ 22
24 in.	8081PEZ 24	8081QEZ 24

8081EZ Ebony Black (EB) Finish		
No Hinges or Bases		
Size	Poly (P)	Quantity (Q)
12 in.	8081PEZ EB 12	8081QEZ EB 12
14 in.	8081PEZ EB 14	8081QEZ EB 14
16 in.	8081PEZ EB 16	8081QEZ EB 16
18 in.	8081PEZ EB 18	8081QEZ EB 18
20 in.	8081PEZ EB 20	8081QEZ EB 20
22 in.	8081PEZ EB 22	8081QEZ EB 22
24 in.	8081PEZ EB 24	8081QEZ EB 24

8082EZ Anochrome (ANO) Finish		
Includes Hinge Base Only		
Size	Poly (P)	Quantity (Q)
12 in.	8082PEZ 12	8082QEZ 12
14 in.	8082PEZ 14	8082QEZ 14
16 in.	8082PEZ 16	8082QEZ 16
18 in.	8082PEZ 18	8082QEZ 18
20 in.	8082PEZ 20	8082QEZ 20
22 in.	8082PEZ 22	8082QEZ 22
24 in.	8082PEZ 24	8082QEZ 24

8082EZ Ebony Black (EB) Finish		
Includes Hinge Base Only		
Size	Poly (P)	Quantity (Q)
12 in.	8082PEZ EB 12	8082QEZ EB 12
14 in.	8082PEZ EB 14	8082QEZ EB 14
16 in.	8082PEZ EB 16	8082QEZ EB 16
18 in.	8082PEZ EB 18	8082QEZ EB 18
20 in.	8082PEZ EB 20	8082QEZ EB 20
22 in.	8082PEZ EB 22	8082QEZ EB 22
24 in.	8082PEZ EB 24	8082QEZ EB 24

Recommended Fasteners	KV Part	Finish	Qty.
#6 x 13/32" Phillips Panhead	1300-23	Zinc (ZC)	1000

Roller

8090P CR Raised Panel Cassette Roller



- Additional protection for raised panel doors

Product	Pack
8090P CR	1 per Poly Pack w/screws

Compatible Hinges

Standard Hinge Kits

Available Pack Configurations			
Hinge Kit (K)	2 Hinges per Kit, 10 Kits per Carton.		
Hinge Pack (P)	40 Hinges per Carton		
Nickel Hinges (for use with 8082P & 8082Q)			
Kit (K)	Pack (P)	Hinge Cup Size	Door Thickness
8080HKEZS	8080HPEZS	35mm	3/4"
8080HKEZL	8080HPEZL	40mm	3/4" Overlay
8080HKEZF	8080HPEZF	35mm	3/4" Free Swing
8085HKEZT	8085HPEZT	40mm	1"
8086HKEZX	8086HPEZX	40mm	1-1/4"

Ebony Black (EB) Hinges (for use with 8082P & 8082Q)			
Kit (K)	Pack (P)	Hinge Cup Size	Door Thickness
8080HKEZS EB	8080HPEZS EB	35mm	3/4"
8080HKEZL EB	8080HPEZL EB	40mm	3/4" Overlay
8080HKEZF EB	8080HPEZF EB	35mm	3/4" Free Swing
8085HKEZT EB	8085HPEZT EB	40mm	1"
8086HKEZX EB	8086HPEZX EB	40mm	1-1/4"

Salice Hinge Kits

Available Pack Configurations		
Hinge Kit (K)	2 Hinges per Kit, 10 Kits per Carton.	
Salice Hinges (for use with 8081P) Nickel Finish		
Kit (K)	Hinge Cup Size	Door Thickness
8080 HKS SAL	35mm	3/4"
8080 HKF SAL	35mm	3/4" Free Swing
8080 HKL SAL	40mm	3/4" Overlay
8086 HKX SAL	40mm	1-1/4" Door

Salice Hinges (for use with 8081P) Black (BLK) Finish		
Kit (K)	Hinge Cup Size	Door Thickness
8080 HKS SAL EB	35mm	3/4"
8080 HKL SAL EB	40mm	3/4" Overlay
8086 HKX SAL EB	40mm	1-1/4" Door

For additional information on our Salice Hinge offerings, please see page 40.

KV
KNAPE & VOGT
800.253.1561
www.kv.com

KV Pack Availability Code
Stock Item
Special Order

8080EZ Series Pivot Door Slides

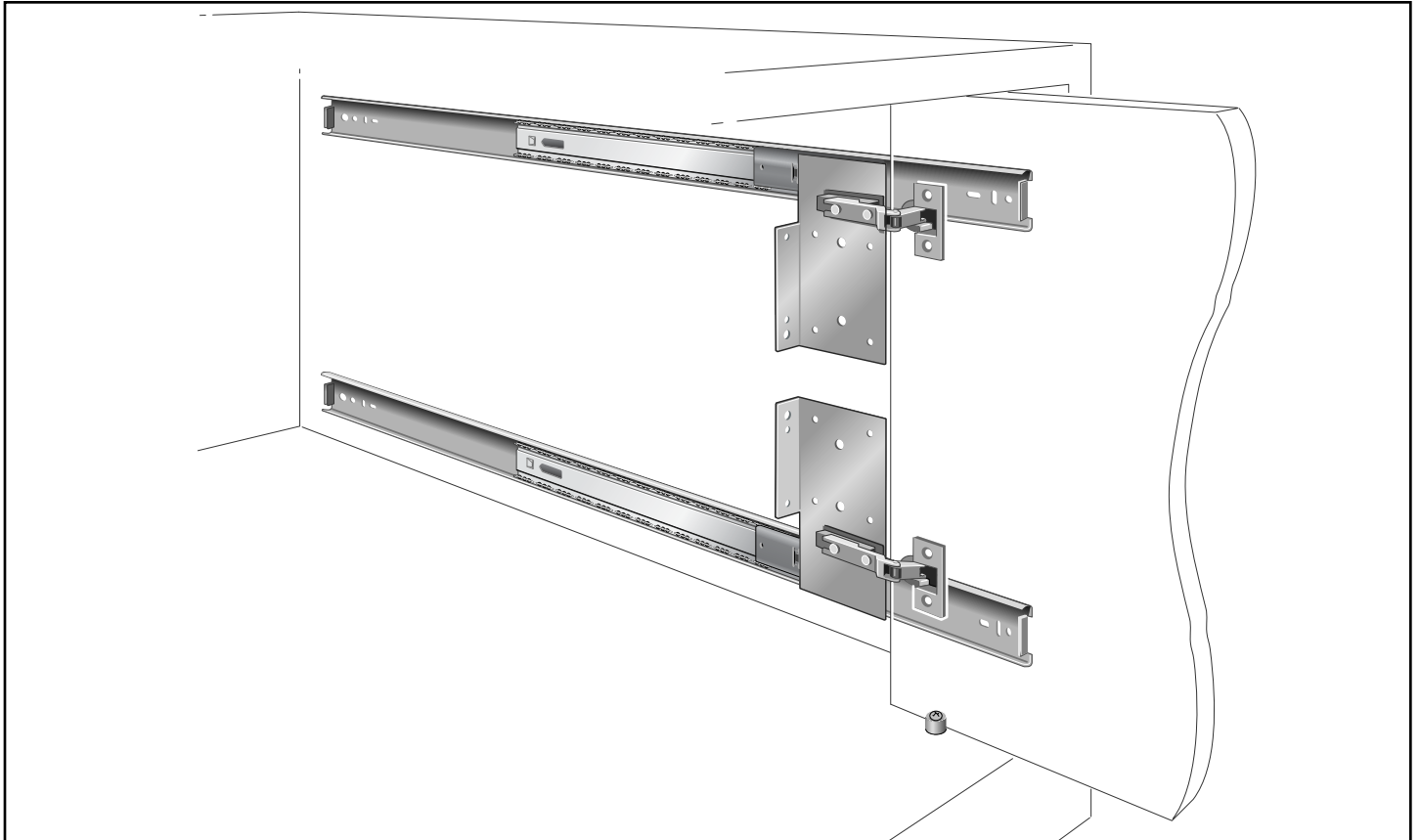

SPECIFICATIONS:

- 30-pound maximum per door.
 - Designed to mount to side of case for pocket door mode. For the flipper mode, door retracts inside of case.
 - Maximum door dimension of 24" x 42".
 - Self-closing three-way adjustable geometric door hinge with single lever disconnect feature.
 - Precision steel ball bearings.
 - Large follower strip mounting plate for rigidity and installation ease.
 - Bright electro-zinc plated and lacquered finish standard. Optional Ebony Black electro-zinc plated lacquer finish.
-

Installation Instructions for KV 8080 Series Pivot Door Slides

READ INSTRUCTIONS FIRST!

These instructions show how to install the KV 8080 Series Pivot Door Slide. Please note that improper installation may void the Knappe & Vogt Limited Lifetime Warranty. To install the slides correctly, follow the enclosed instructions, use only KV hardware and make no modifications. If you have questions or need additional information, please contact Knappe & Vogt customer service.

Typical Application

- Obtain appropriate hinge based on door thickness and operational requirements.
- Recommended maximum door dimension: 24" x 42". For larger doors, consult **KV 8081 Pivot Door Instructions** later in this document.
- Recommended maximum door weight: 30 lbs.
- Designed to mount vertically or horizontally.

Step 1. Install hinge cup in cabinet door

Determine location of hinge hole centers. Bore two holes at back inside edge of door following chart recommendations (**chart 2**) for bore diameter and edge-bore distance based on hinge being used. Always bore on a test block first to verify hinge cup locations. Install hinges in door.

Step 2. Follower strip fabrication and attachment

- Cut a follower strip 2-3/4" to 3" wide, x 1/2" minimum thickness. Size the length 2" less than hinge cup centerline distance (**dimension A** as shown on **figure 1 & 2**).
- Attach hinged door assembly to hinge bases on slides by snapping them in place.
- Center follower strip across mounting plates and fasten screws. For maximum rigidity, install six screws in each mounting plate.

Step 3. Install slide and follower strip assembly to inside of case.

- Detach door and hinges from the slide and follower strip assembly, by pulling upward on the release lever located at the end of the hinge.
- Centralize slide and follower strip assembly into case, keeping each slide center line to edge of case distance equal to **dimension B** (**figure 1 & 2**) plus suggested gap dimension of 1/8" minus 5/8" allowance for hinge offset.
- Slides must be parallel to case edge.
- Slides must also be set back from the front of the case a distance equal to the door thickness plus 1/4", as shown (**figure 4**). Measure this dimension from the front edge of the slide roller.
- Mount slides first through slotted holes to allow for adjustment, if needed. When final adjustments are complete, install additional screws in fixed holes.

Step 4 Door guide roller installation.

- Proper operation requires precise roller location – drill pilot hole for screw located from case edges as shown (**figure 4**).
- Secure guide roller using flat-head wood screw supplied. Tighten screw enough to still allow roller to freely turn.

IMPORTANT:

Roller assembly should not bind on door. Always install the 8080Pivot Door slide using bottom guide roller provided with slide. If roller is missing or lost, contact KV customer service for replacement – DO NOT substitute other rollers. This roller, when properly installed, assures the smoothness of operation. When improperly installed, the slides could be damaged. Locate the rollers as shown.

Step 5 Hinged door attachment and adjustment.

- Clip door hinges to hinge base by aligning hooks on the underside of the hinge with the front tongue on the hinge base and then pressing on the rear portion of the hinge until spring lever engages.
- Carefully close door and observe for any needed adjustment, then open door to adjust hinge as required.
- Turn hinge screws to adjust door in all three directions.
- **Horizontal** adjustment screw—adjusts door side gap clearance. **Do not over adjust—this screw MUST NOT be tight.**
- **Depth** adjustment screw—adjusts door face in and out (flush with case edge). **Screw must be tight.**
- **Vertical** adjustment screw—adjusts door up and down (top and bottom gap clearance). **Screw must be tight.**
- Door removal can be accomplished by pulling the release lever located at the end of the hinge upward.

Alternate Installation Instructions for KV 8081 Pivot Door Slide

Step 2 Hinge base attachment

- Fasten appropriate hinge bases* to mounting plates by means of two #8-32 x 1/4" long flat-head self-tapping screws (provided). See **figure 5** for hole location.
- * Requires 0mm thick wing type hinge base. The self-tapping mounting screws provided may not be compatible with all manufacturers' hinge bases. **If a substitute screw is used, check for proper thread engagement and clearance above the ball retainer.** An optional screw (KV# 200283) is available that is 5/16" in length.

Alternate Installation Instructions for Large Door Applications

For large door installation, use the following instructions in place of Step 3 in the Typical application section (**figure 7 & 8**).

Step 3 Follower strip fabrication and attachment

- Cut follower strip 2-3/4" to 3" wide x 1/2" minimum thickness. Size the length to extend to edge of follower strip mounting plates.
- Center follower strip across mounting plates and fasten screws. For maximum rigidity, install six screws in each mounting plate.
- Install hinge bases to follower strip located over slide channel centerline. Be sure hinge base centerline distance is equal to centerline distance of hinges mounted on door.

figure 1

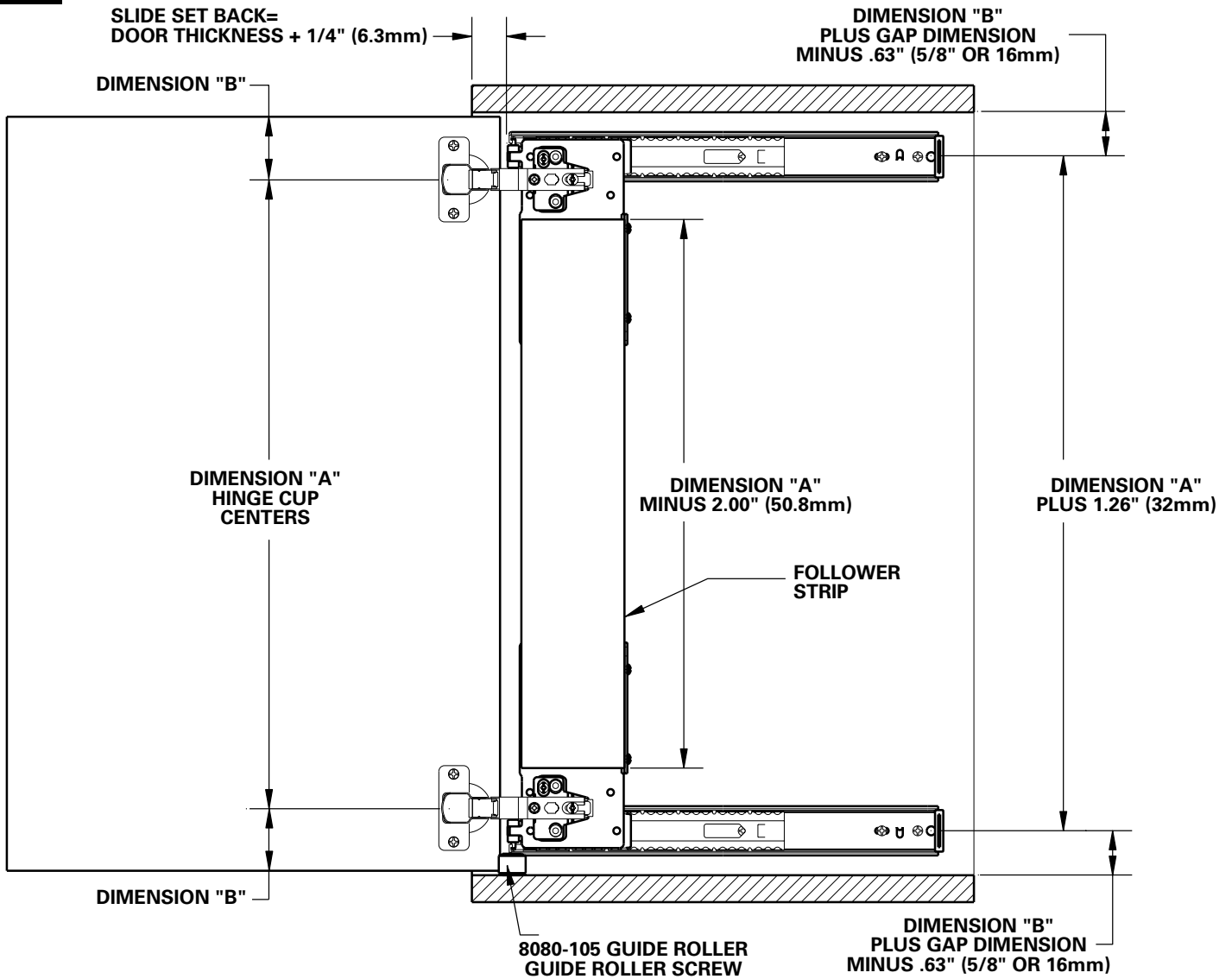

figure 2 DOOR PREPARATION

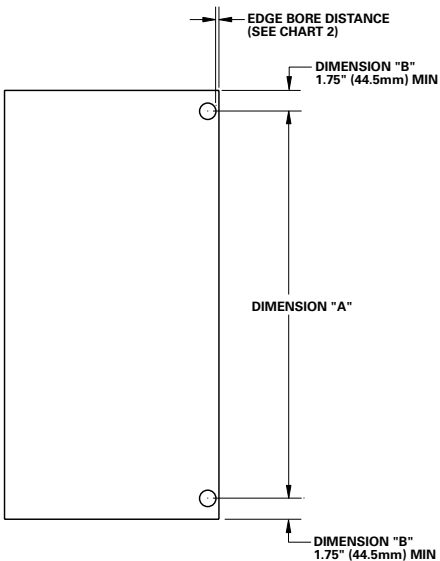

figure 3 HINGE ADJUSTMENT

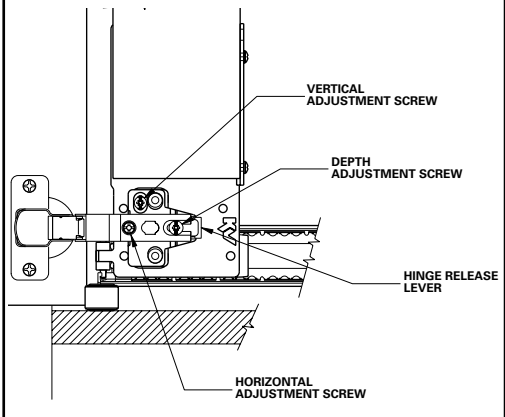

figure 4 DOOR GUIDE ROLLER INSTALLATION

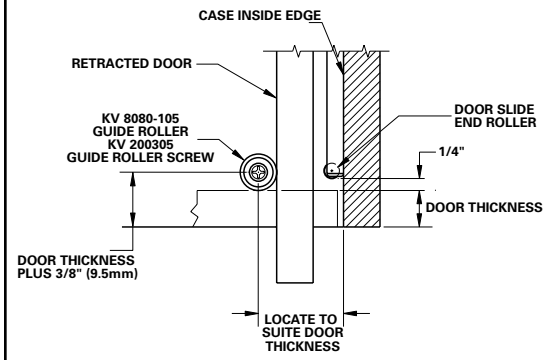
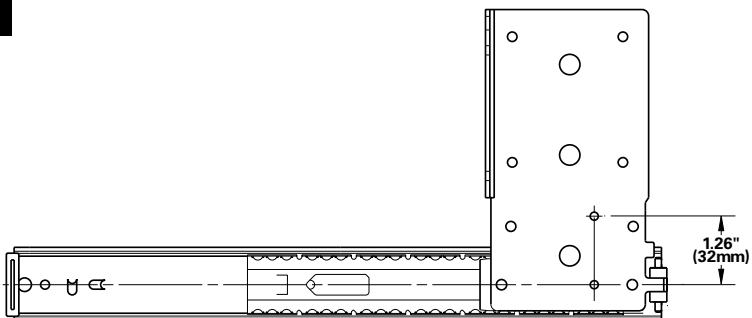

figure 5



Typical Hinge Specification

For doors 5/8" - to 3/4"-thick, hinges are available from a variety of other manufacturers, including Mepla, Blum, Grass, Salice and Hettich. These manufacturers are familiar with the KV 8081 slide and can assist you in selecting the appropriate hinge for your application.

For typical applications, KV recommends the following specification.

Hinge: 95° half overlay self-closing thick door hinge.

Hinge Base: 0mm thick, 32mm wing type hinge base with 37mm setback.

figure 6

Overlay Door Installation with 8080L Hinge (3/4" Thick Doors Only)
Same as standard installation except for slide placement (set back) from front edge of case.

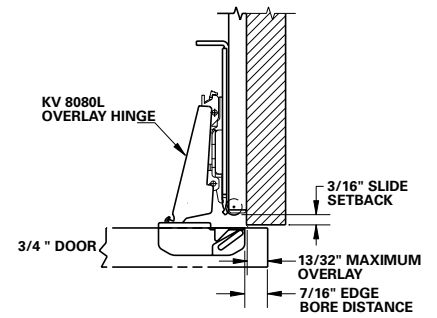

figure 7

Large Door Application Example (3/4" Thick Doors Only)

- 0mm Thick Hinge Base
- 0° Crank Hinge
- 40mm Hinge Cup

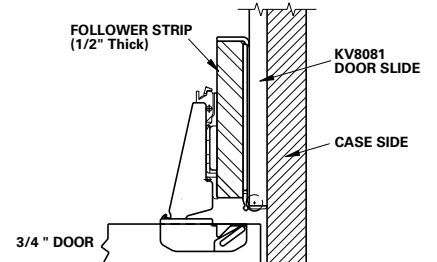

figure 8

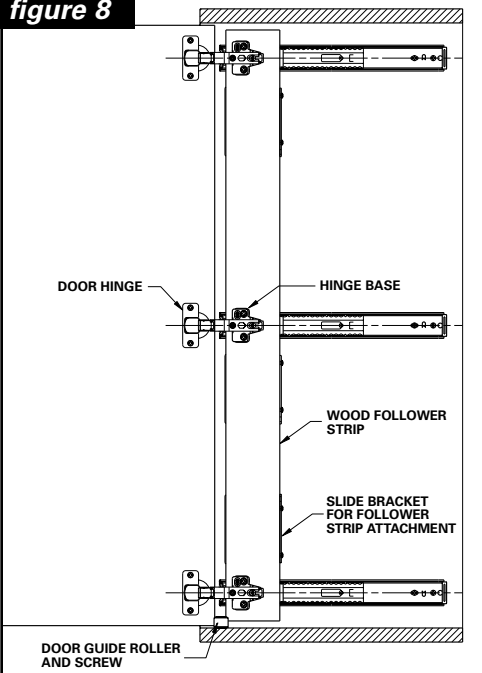

chart 1

Size	L	Approx. Door Conceal*	Approx. Cabinet Depth**
12"	12-1/8"	9"	12-3/8"
14"	14-18"	11"	14-3/8"
16"	16-1/8"	13"	16-3/8"
18"	18-1/8"	14"	18-3/8"
20"	20-1/8"	16"	20-3/8"
22"	22-1/8"	18"	22-3/8"
24"	24-1/8"	20"	24-3/8"

** Door fully retracted into case
*** Add thickness of door to determine minimum

figure 9

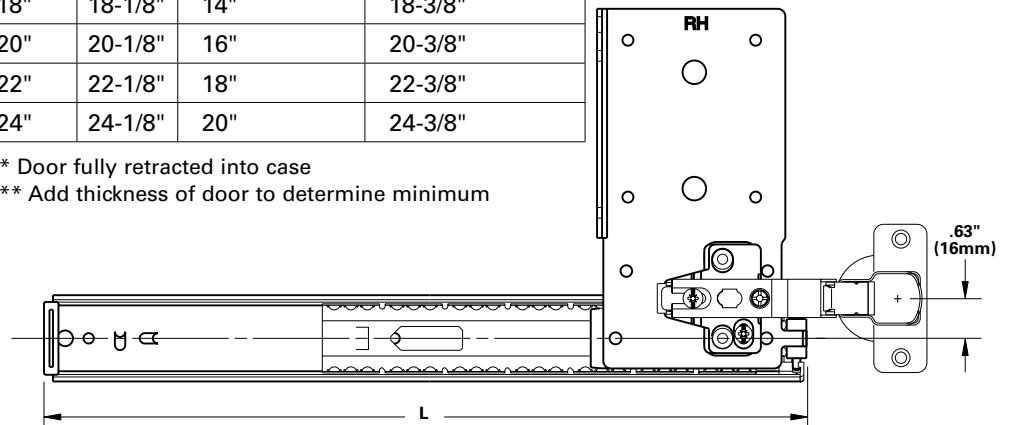

figure 10

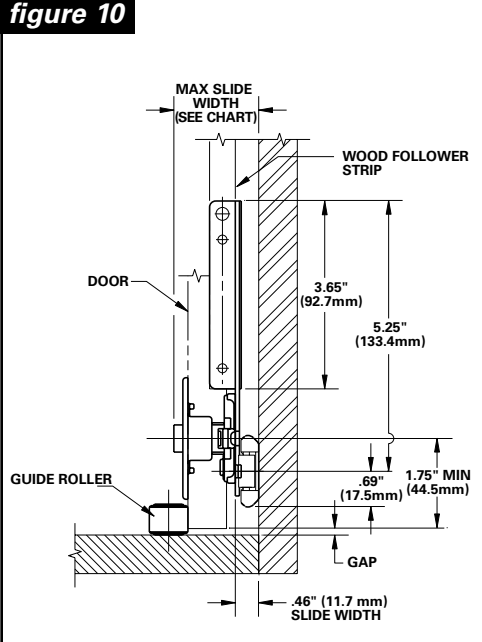

figure 11

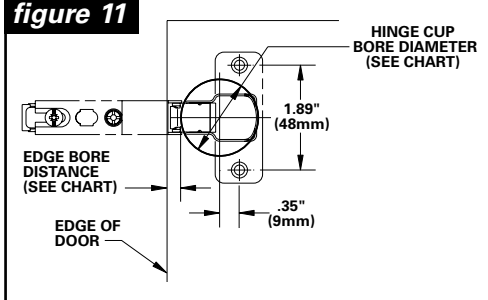

figure 12

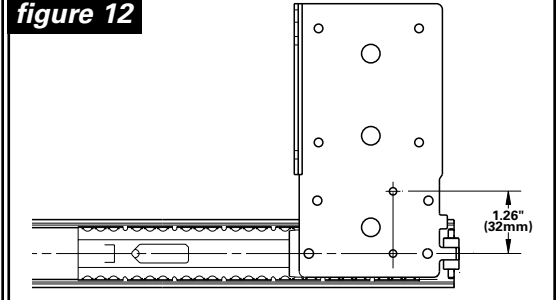
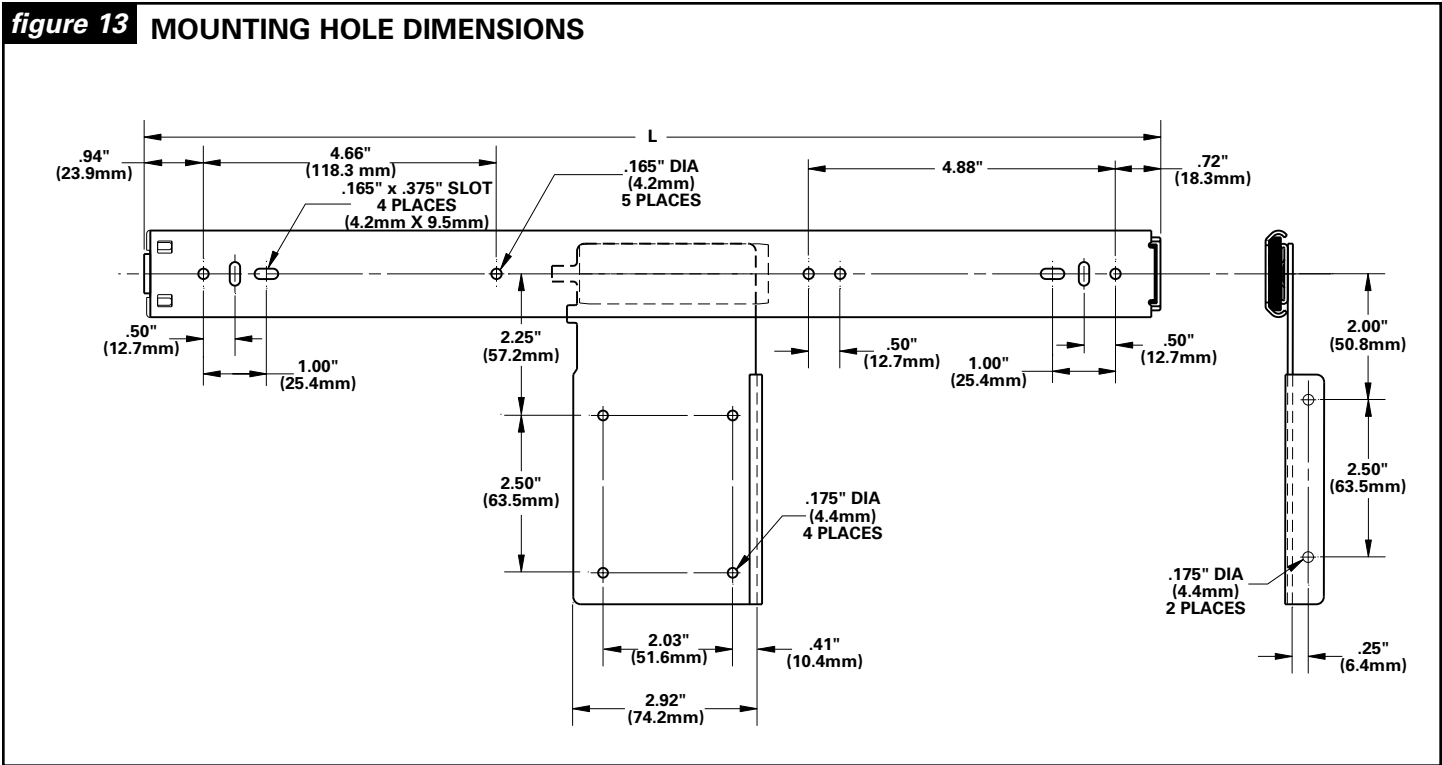

chart 2

Hinge Option	Description	Door Thickness	Edge Bore Distance	Hing Cup Bore Dia.	Max. Slide Width incl. Hinge for Partition Installations	Partial Overlay
8080	Standard Hinge	3/4" (19mm)	1/4" (6mm)	1-3/8" (35mm)	1-23/32 (43.7mm)	N/A
8080FS	Standard Hinge w/ free swing knuckle	3/4" (19mm)	1/4" (6mm)	1-3/8" (35mm)	1-23/32 (43.7mm)	N/A
8080L	Overlay Door	3/4" (19mm)	7/16" (11mm)	1-37/64" (40mm)	1-23/32" (43.7mm)	13/32" (10.3mm)
8085	Thick Door	1" (25.4mm)	5/16" (8mm)	1-37/64" (40mm)	2-3/32" (53.2mm)	N/A
8086	Extra Thick Door	1-1/4" (32mm)	1/2" (12.7mm)	1-37/64" (40mm)	2-13/32" (61mm)	N/A

figure 13 MOUNTING HOLE DIMENSIONS



Limited Lifetime Warranty

Knape & Vogt Manufacturing Company guarantees its drawer slides and builder's hardware products against failure or defects for so long as the purchaser or end user owns them. This warranty is void if any damage to the product is due to misuse, neglect, accident, improper installation or any uses contrary to the instructions accompanying the product. This warranty covers the cost of the defective part and not the cost of removal, installation or other incidental charges. The foregoing are the purchaser's exclusive remedies. Knape & Vogt Manufacturing Company assumes no liability for special or consequential damages.

Replacement product may be obtained by returning the product, transportation charges prepaid, together with a receipt of purchase or other documents acknowledging the sale of the product to the Knape & Vogt Manufacturing Company, Attention: Customer Service Department.

The warranty set forth above is in lieu of any other warranties, express or implied, including warranties of merchantability and fitness for use.



KNAPE & VOGT

2700 Oak Industrial Drive NE
Grand Rapids, MI 49505

800.253.1561 • 616.459.3311 • fax 616.459.3290

www.kv.com

